

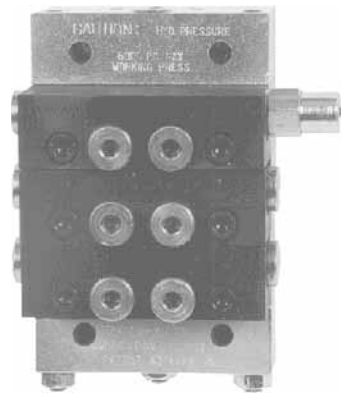

Trabon® Series-Flo Divider Valve Accessories & Parts

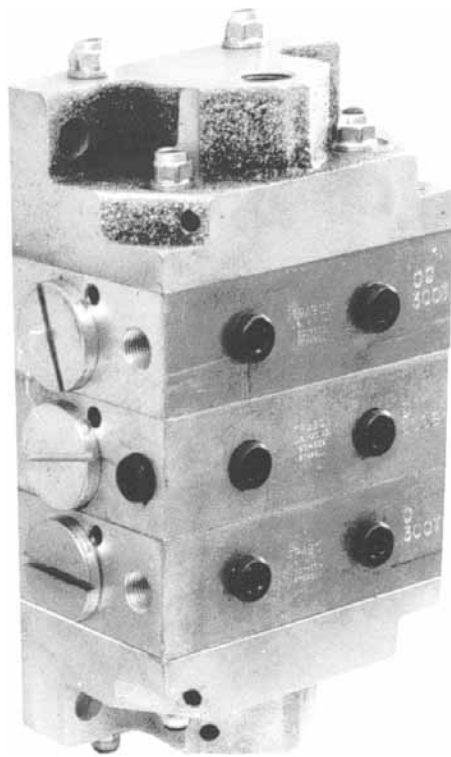

Series-Flo Divider Valve Parts

Divider Valve	Part Numbers (Old Part Numbers)						
	MJ	MJ-SS	MS/MH	MS (Nickel)	MX	MXP	MGO
Intermediate Gasket 1 Per Section	557514 (510-998-002)	557514 (510-998-002)			557509 (510-933-001)		
Enclosure †			O-Ring (Buna) 556568 (422-210-040)	O-Ring (Buna) 556568 (422-210-040)	O-Ring (Viton) 556572 (422-240-080)	O-Ring (Viton) 556572 (422-240-080)	
Plug Seals 2 Per Section	Gasket 557507 (510-681-000)	Gasket 555745 (439-077-235)	Gasket 557717 (527-000-240)	Gasket 557717 (527-000-240)	Gasket 557323 (500-776-000)	Gasket 557323 (500-776-000)	O-Ring – (422-012-170)
O-Rings 9 Per Section Except MGO			Std (Buna-N) 556540 (422-010-060)	Buna-N 556540 (422-010-060)		Std (Viton) 557773 (527-300-510) 90 Duro	Viton & Buna-N 556554 (422-040-110) (4) 556555 (422-040-120) (2) 556556 (422-040-130) (2) 556558 (422-040-150) (1) 555712 (423-700-086) (1) Repair Kit 563926 (560-001-950) Contains all of above O-Rings for one valve section
Tie Rods Qty Per Divider Valve Assembly	(2)	(2)	(3)	(3)	(4)	(3)	(2)
No. of Sections in Divider Valve							Upper Rods
3	557515 (510-999-030)	558917 (510-999-130)	563429 (527-001-930)	– (527-003-290)	557488 (510-505-030)	557766 (527-300-270)	560591 (510-665-030)
4	557516 (510-999-040)	– (510-999-140)	563430 (527-001-940)	557742 (527-003-300)	557489 (510-505-040)	557767 (527-300-280)	thru
5	557517 (510-999-050)	– (510-999-150)	563431 (527-001-950)	557743 (527-003-310)	557490 (510-505-050)	557768 (527-300-290)	560598 (510-665-100)
6	557518 (510-999-060)	– (510-999-160)	563432 (527-001-960)	557744 (527-003-320)	557491 (510-505-060)	557769 (527-300-300)	Lower Rods
7	557519 (510-999-070)	– (510-999-170)	563433 (527-001-970)	558932 (527-003-330)	557492 (510-505-070)	557770 (527-300-310)	560600 (510-666-030)
8	557520 (510-999-080)		563434 (527-001-980)	560938 (527-003-340)	557493 (510-505-080)	557771 (527-300-320)	thru
9					560576 (510-505-090)	557772 (527-300-330)	560606 (510-666-100)
10					560577 (510-505-100)	563520 (527-300-340)	
Tie Rod Nuts Qty Per Divider Valve Assembly	556371 (410-440-010)	558633 (410-702-002)	556371 (410-440-010)	558633 (410-702-002)	557494 (510-506-001)	555406 (410-440-020)	557494 (510-506-001)
Mounting Screws 2 Per Section			556513 (419-140-070)	555618 (419-700-020)		556516 (419-160-080)	
Mounting Bars and Plates	See L15126		See L15126		See L15126		
Cycle Ind. Pin Repair Kit †	Gasket 563948 (560-002-987)		O-Ring (Buna-N) 563929 (560-002-055) Gasket 563928 (560-002-050)		O-Ring (Viton) 563917 (560-001-720)* Gasket – (560-001-710)	O-Ring (Viton) 563917 (560-001-720) Ind. Body 563523 (527-300-830)	Ind. Body 563274 (510-612-001)

* 1985 and Later

† MS/MH dated L94 and later use o-ring seal; K94 and earlier use metal gasket.
MXP dated K94 and later use o-ring seal; J94 and earlier use metal gasket.

Singling and Cross Porting Bar Assemblies

Used with MJ & MX Type Dividers

Singling Kits externally convert a “T” (Twin Outlet) section to an “S” (Single Outlet) section.

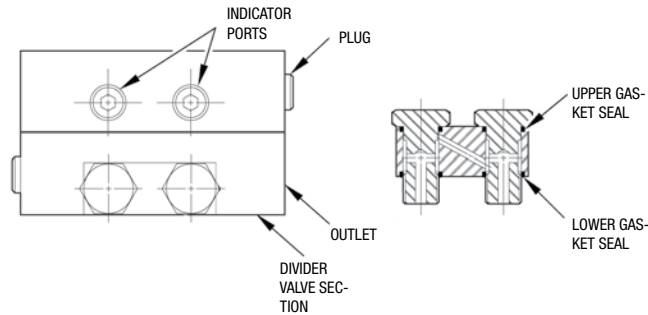

Crossporting Kits externally combine the output of two (2) adjacent sections.

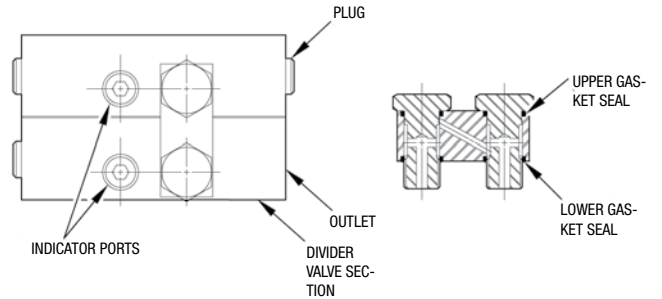
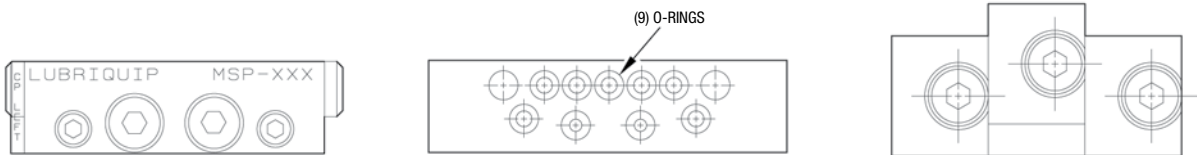

Plate Type Single and Crossport Kit

Used with MSP & MXP Type Dividers



ORDERING INFORMATION

PART NUMBERS (OLD PART NUMBERS)								
Divider	Singling Kit	Cross Port Kits			Gasket Upper Seal (Bar Type)	Gasket Lower Seal (Bar Type)	90 Duro Viton O-Ring (plate Type)	Valve Block Mounting Screw-Long
		Right Side	Left Side	Both Sides				
MJ	562915 (189-000-050)	562914 (189-000-040)	562914 (189-000-040)	-	557359 (503-816-010)	557503 (510-657-000)	-	-
MJ-SS	-	-	-	-	-	-	-	-
MSP	563469 (527-005-320)	563469 (527-005-320)	563470 (527-005-330)	563471 (527-005-340)	-	-	557722 (527-000-840)	556514 (419-140-080)
MS (Nickel)	-	-	-	-	-	-	-	-
MX	562916 (189-000-060)	562917 (189-000-090)	562917 (189-000-090)	-	557511 (510-966-000)	557512 (510-968-000)	-	-
MXP	-	563525 (527-300-980)	563524 (527-300-970)	563526 (527-300-990)	-	-	557773 (527-300-510)	555601 (419-160-090)
MXP (Nickel)	-	-	-	-	-	-	-	-
MGO	-	-	-	-	-	-	-	-

Cycle Indicators

Cycle Indicators provide a means of visually monitoring lube flow thru the system. The pin type cycles in and out when lubricant is flowing. Movement of the pin is caused by the piston (the two are attached) so that when the piston moves the indicator pin in and out once, the entire divider valve has cycled. This accessory must be ordered as part of a divider section. Refer to individual divider valve product sheet for ordering code. The magnetic type has six steel balls, within a transparent housing, that move back and forth during normal cycling of the valve. This accessory replaces the piston enclosure plug and can be used on any size valve section.

Valve Series	O-Ring Sealed	
	Part No.	Old Part No.
MS/MH	563251	509-932-522
MX/MXP	563260	509-932-720
MGO	-	509-932-836

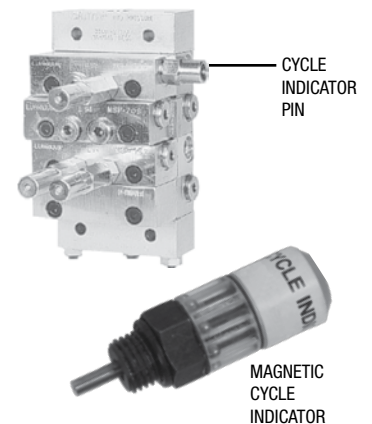

Cycle Counters - Ordering Information

The function of a **Cycle Counter** is to give assurance that the lubricant is flowing thru the system. Every "count" indicates one complete cycle of the divider valve. Visual inspection and/or recording of counts provides a constant check on the performance of your lubricant system and the pump. (Universal Counter - **Part Number - 563444 (527-002- 410)** Can be used on MJ, MS, MH, MX and MXP divider valve assemblies.

Important - the cycle counter must be attached to a section which is equipped with a cycle indicator pin. If you are adding the counter to an existing system that does not have such a section, you must order it to replace an existing section somewhere in the system. Refer to individual divider valve product sheets for ordering information.



Cycle Switches - Ordering Information

The function of a **Cycle Switch** is to electrically give assurance that the lubricant is flowing thru the system. Actuated by a cycle pin, switch can be wired to various controls.

Important - cycle switch must be attached to a section which is equipped with a cycle indicator pin. When adding the cycle switch to an existing system that does not have a section with a cycle indicator pin, you must order such a section to replace an existing section somewhere in the system. Refer to individual divider valve sheets for ordering information.

PART NUMBERS (OLD PART NUMBERS)						
Series-Flo Divider Valves	MJ	MS/MH	MS (Nickel)	MX	MXP	MGO
Cycle Switch and Bracket Ass'y SPDT	563272 (510-599-000)	563272 (510-599-000)	563272 (510-599-000)	563272 (510-599-000)	563272 (510-599-000)	563269 (510-250-000)
	Electrical Ratings: 15 amps at 125, 250 and 480 VAC 1/2 amp at 125 VDC, 1/4 amp at 250 VDC, 6.0 amps at 24 VDC Non-Inductive					
Replacement Switch	557781 (529-726-001)	557781 (529-726-001)	557781 (529-726-001)	557781 (529-726-001)	557781 (529-726-001)	557781 (529-726-001)
Cycle Switch and Bracket Ass'y DPDT	564357 (510-577-000)	564357 (510-577-000)	564357 (510-577-000)	564357 (510-577-000)	564357 (510-577-000)	- (510-269-001)
	Electrical Ratings: 10 amps at 125 or 250 VAC .3 amp at 125 VDC or .15 amp at 250 VDC					
Replacement Switch	- (510-741-000)	- (507-741-000)	- (508-741-000)	- (507-741-000)	- (507-741-000)	- (507-741-000)
Replacement Bracket for either SPDT or DPDT Switch Ass'y	557546 (511-968-002)	557546 (511-968-002)	557546 (511-968-002)	557546 (511-968-002)	557546 (511-968-002)	560573 (510-246-002)
Moisture Resistant Cycle Switch w/6 ft Cable and Bracket Ass'y SPDT	563273 (510-599-200)	563273 (510-599-200)	563273 (510-599-200)	563273 (510-599-200)	563273 (510-599-200)	- -
	Electrical Ratings: 5 amps at 125 or 250 VAC Wire Code for Moisture Resistant Switch: BK (Com), Red (N.C.), WH (N.O.), GN (Ground)					
Replacement Switch w/6 ft Cable	557782 (529-726-200)	557782 (529-726-200)	557782 (529-726-200)	557782 (529-726-200)	557782 (529-726-200)	- -

Proximity Cycle Switches - Ordering Information

The **Proximity Cycle Switches** are magnetically operated single throw switches that sense the movement of the divider valve piston when it is cycling. Each proximity cycle switch provides a signal that is used to monitor the system. It is available in three basic types with specifications and features as listed on page 5.

Proximity Switches Con't

The **Reed Type Proximity Switch** is available in an unattached version for oil only applications for MS, MH, and MGO at pressures up to 518 bar (7500 psi) and with cycle rates under 60 cycles per minute.

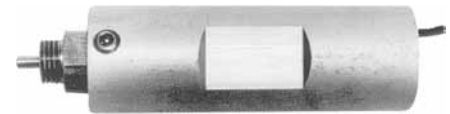

REED TYPE PROXIMITY SWITCH

The **Field Sensitive Magnetic Proximity Switch** is a dry contact, ceramic magnet operated switch. It can be used in either grease or oil applications, at cycle rates up to 200 cpm and at pressures that do not exceed 242 bar (3500 psi). The switch is available in three sizes for MS/MH, MX/MXP and MGO and is not limited to valve section size. Mating plugs in 6 ft and 12 ft lengths are available. It is also available in an explosion-proof version (with 6 foot wire) for MS/MH divider valves.

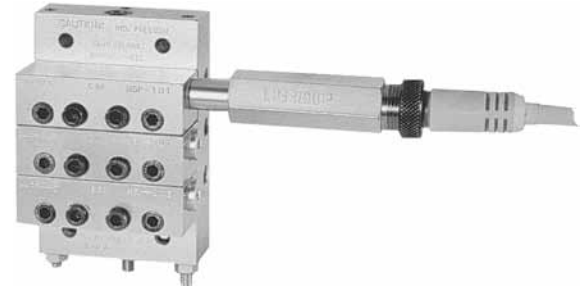

FEEDER WITH FIELD SENSITIVE PROXIMITY SWITCH ATTACHED

The **Magnetic Operated Proximity Switch** is not limited to valve size and contains a miniature snap-action switch that is tripped by attraction of the internal magnet to the moving divider piston. A 24 VDC only version has built-in light emitting diodes (LEDs) for local verification of cycling and is available with 3-pin, 4-pin, or 5-pin connectors. Similar units without LEDs are suitable for DC or AC operation and also include an explosion-proof version with a 6 ft. pigtail lead. These switches may be used at pressures up to 518 bar (7500 psi) and at cycle rates not exceeding 150 cpm.

Description	No. of Pins	Type Seal	Part Numbers (Old Part Numbers)				
			MS	MH	MX	MXP	MGO
Unattached Reed Type (oil only) 10 mA @ 120 VAC 24 mA @ 24 VDC 10,000,000 Cycle Life	1/2 NPT w/ Leads (Exp Proof)	O-Ring	563427 (527-001-231)	563427 (527-001-231)	- -	- -	- (570-155-001)
Field Sensitive Magnetic Type 3-pin and 5-pin (AC only) 2A @ 120/240 VAC 4-pin (DC only) 0.1A @ 28 VDC 150,000,000 Cycle Life	3	O-Ring	557741 (527-003-251)	557741 (527-003-251)**	563476 (527-005-520)	563476 (527-005-520)	563970 (570-999-060)
		Gasket*	- -	- -	563969 (570-999-050)	563969 (570-999-050)	- -
	5	O-Ring	557746 (527-004-111)	557746 (527-004-111)**	564399 (527-005-190)	564399 (527-005-190)	- (570-999-220)
		Gasket*	- -	- -	- (570-999-210)	- (570-999-210)	- -
	4	O-Ring	557747 (527-004-112)	557747 (527-004-112)**	558938 (527-007-140)	558938 (527-007-140)	563495 (527-007-120)
Pigtail Lead (Exp. Proof)	O-Ring	557745 (527-003-431)	557745 (527-003-431)**	564401 (527-006-150)	564401 (527-006-150)	- -	
Magnetic Type with LEDs 5A @ 24 VDC 10,000,000 Cycle Life	3	O-Ring	563478 (527-005-690)	563478 (527-005-690)	- -	- -	- -
	5	O-Ring	563477 (527-005-670)	563477 (527-005-670)	- -	- -	- -
Magnetic Type 5A @ 24 VDC 5A @ 120/240 VAC 10,000,000 Cycle Life	3	Gasket*	- -	- -	563486 (527-006-130)	563486 (527-006-130)	- -
	5	O-Ring	563484 (527-006-050)	563484 (527-006-050)	564400 (527-006-140)	564400 (527-006-140)	- -
	Pigtail Lead (Exp. Proof)	O-Ring	563485 (527-006-060)	563485 (527-006-060)	- -	- -	- -
Field Sensitive Magnetic Type 25 ma @ 24 VDC M12 x 1, 4-pin (DC only) 10,000,000 Cycle Life	4	O-Ring	563500 (527-007-263)	563501 (527-007-273)	- -	- -	- -

* Consult your distributor for availability.

Notes: ** Pressure must be limited to 242 bar maximum (3500 psi).

Request bulletin 15600 for additional information on Proximity Cycle Switches.

Proximity Switches Con't

Connection Cables for:					
3-Pin Proximity Switch			5-Pin Proximity Switch		
Connector	Length (ft)	Part Number	Connector	Length (ft)	Part Number
Straight	6	558021 (570-999-080)	Straight	6	558023 (570-999-160)
Straight	12	558022 (570-999-090)	Straight	12	558024 (570-999-170)
			90°	6	558965 (570-999-390)
4-Pin (M12 x 1)					
Straight	7	568738 (808107)	90°	6.6	— (570-999-600)

Trabon Performance Indicators are pressure sensitive devices which pinpoint excessive pressure by causing an indicator pin to protrude or by releasing lubricant to atmosphere. If the lube system operation must stop when a lubrication blockage occurs, then a seal-tight type of indicator should be used. If the lube system must continue to operate in spite of the blockage, the vent-to-atmosphere type of performance indicator should be used.

FEATURES

- Precise location of lube line blockage / high pressure.
- Allows lube system to shut down or continue operation when lube line blockage occurs.
- Option of manual or automatic resetting performance indicators.

OPERATION

Reset Indicator:

Reset indicators may be used in master and/or secondary divider valves. A high pressure condition will cause the piston inside the indicator to move up, compressing a spring and forcing the pin to protrude. As high pressure is relieved the spring will force the piston down, while the indicator pin is held in place by an o-ring until it is reset manually.

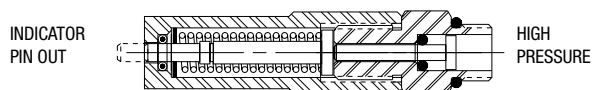

Automatic Relief Indicator:

These indicators can be used in master and secondary divider valves. By venting lubricant-to-atmosphere, automatic relief indicators can “pinpoint” lube line blockage, while allowing the rest of the lube system to operate. Inside the indicator is a piston which covers the lube vent in the indicator, a lube line blockage creates excessive pressure and forces this piston up, uncovering the outlet, and allowing lubricant to escape through the vent. When the blockage is corrected, a spring forces the piston back down covering the outlet and causing the indicator to automatically reset itself. This indicator allows the rest of the lube system to operate if a lube line is blocked.

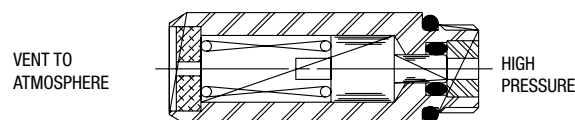

OPERATION

Blowout-To-Atmosphere Indicator:

The blowout-to-atmosphere indicator can be used in master and secondary divider valves. Excessive pressure due to a lube line blockage will cause an internal disc to rupture. Lubricant will escape through the ruptured disc to atmosphere. This pinpoints the blocked line and allows the rest of the system to continue to operate. When the blockage is corrected, the ruptured disc must be replaced.

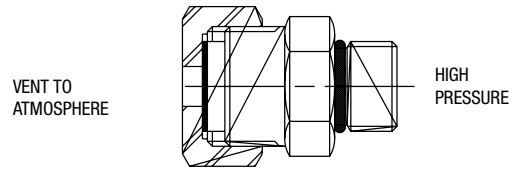

Rupture Indicator:

Rupture indicators are used on MH divider valves where lube system pressures exceed 173 bar (2500 psi). The high pressure from lube line blockage causes a disc to rupture. The lubricant then forces an indicator pin to protrude, locating the blockage. The high pressure backs up through the system and trips a pressure switch to shut the system off. When fault is corrected, the disc must be replaced and pin reset manually.

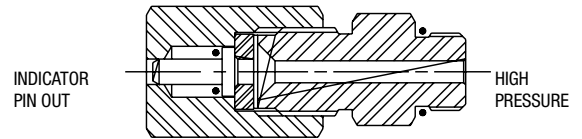

ORDERING INFORMATION

Order performance indicator by part number and description. Disc are color coded for burst pressure and can be ordered by part number and description. Refer to the following tables.

Automatic Relief Indicator				
bar	(PSI)	1/8 NPTF (OLD STYLE) For MJ, MH, MS, MXP	1/8 NPSF w/O-RING SEAL (*NEW STYLE) MH, MS, MXP	1/4 NPTF For MX+
52	(750)	563163 (508-310-075)	563170 (508-310-415)	563156 (508-210-075)
69	(1000)	563164 (508-310-100)	563171 (508-310-425)	563157 (508-210-100)
86	(1250)	563165 (508-310-125)	563172 (508-310-435)	- -
104	(1500)	563166 (508-310-150)	563173 (508-310-445)	563158 (508-210-150)
138	(2000)	563167 (508-310-200)	563174 (508-310-455)	563159 (508-210-200)
173	(2500)	563168 (508-310-250)	563175 (508-310-465)	563160 (508-210-250)
207	(3000)	563169 (508-310-300)	563176 (508-310-475)	563161 (508-210-300)

+ For old-style MGO Dividers, use with 3/8x1/4 bushing, Trabon 556404 (412-170-030).

* Applies to product with date code L-94 (November 1994) or later.

Request Bulletin L15401 for further information on Performance Indicators.

ORDERING INFORMATION

Order performance indicator by part number and description. Disc are color coded for burst pressure and can be ordered by part number and description. Refer to the following tables.

Reset Indicator with Memory					
bar	(PSI)	1/8 NPTF (OLD STYLE) For MJ, MH, MS, MXP	1/8 NPSF w/O-RING (*NEW STYLE) MH, MS, MXP	1/4 NPTF For MX+	7/8-14 w/O-RING (*NEW STYLE) MGO
17	(250)	563231 (509-931-010)	563252 (509-932-590)	563239 (509-932-010)	- (509-932-018)
36	(500)	563232 (509-931-020)	563253 (509-932-600)	563240 (509-932-020)	- (509-932-028)
52	(750)	563233 (509-931-030)	563254 (509-932-610)	563241 (509-932-030)	- (509-932-038)
69	(1000)	563234 (509-931-040)	563255 (509-932-620)	563242 (509-932-040)	- (509-932-048)
104	(1500)	563235 (509-931-050)	563256 (509-932-630)	563243 (509-932-050)	564200 (509-932-058)
138	(2000)	563236 (509-931-060)	563257 (509-932-640)	563244 (509-932-060)	- (509-932-068)
173	(2500)	563237 (509-931-070)	563258 (509-932-650)	563245 (509-932-070)	- (509-932-078)

Blowout Indicator						
MH 1/8 NPT	MX 1/4 NPT	Replacement Disc (11/16" dia.)	Color	bar	(PSI)	
- -	563179 (509-206-100)	557433 (509-292-000)	Yellow	100	(1450)	
- -	563182 (509-206-120)	557434 (509-293-000)	Red	121	(1750)	
- -	563184 (509-206-160)	557436 (509-295-000)	Aluminum	162	(2350)	
- -	563185 (509-206-200)	557438 (509-297-000)	Blue	204	(2950)	

Rupture Indicator						
MH 1/8 NPTF (OLD STYLE)	1/8 NPSF w/O-RING (*NEW STYLE) MH	MX 1/4 NPTF	Replacement Disc (3/8" dia.)	Color	bar	(PSI)
563228 (509-499-620)	563229 (509-499-625)	- -	557422 (509-277-000)	Green	193	(2800)
563220 (509-499-100)	563221 (509-499-105)	- -	557423 (509-278-000)	Yellow	288	(3700)
564355 (509-499-120)	563222 (509-499-125)	- -	557424 (509-279-000)	Red	317	(4600)
563223 (509-499-140)	563224 (509-499-145)	- -	557425 (509-280-000)	Orange	380	(5500)
563225 (509-499-160)	563226 (509-499-165)	- -	557427 (509-282-000)	Pink	442	(6400)

Indicator port adapter 527-300-850 1/8 NPSF with o-ring to 7/16-20 SAE O-Ring seal port.

+ For old-style MGO Dividers, use with 3/8x1/4 bushing (Trabon 556404 412-170-030).

* Applies to product with date code L-94 (November 1994) or later.

Request Bulletin 15401 for further information on Performance Indicators.

All written and visual data contained in this document are based on the latest product information available at the time of publication. Graco reserves the right to make changes at any time without notice.

Contact us today!

To receive product information or talk with a Graco representative,
call 800-533-9655 or visit us online at www.graco.com.

